

MT1841/SS

STAINLESS STEEL MINI HOT & COLD WATER FAUCET WITH CONTEMPORARY ROUND BODY & HANDLES



Mountain
Plumbing Products

SPECIFICATION SHEET

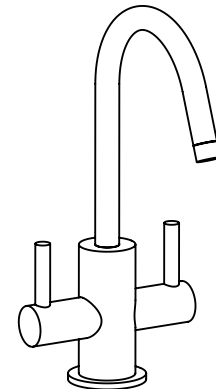
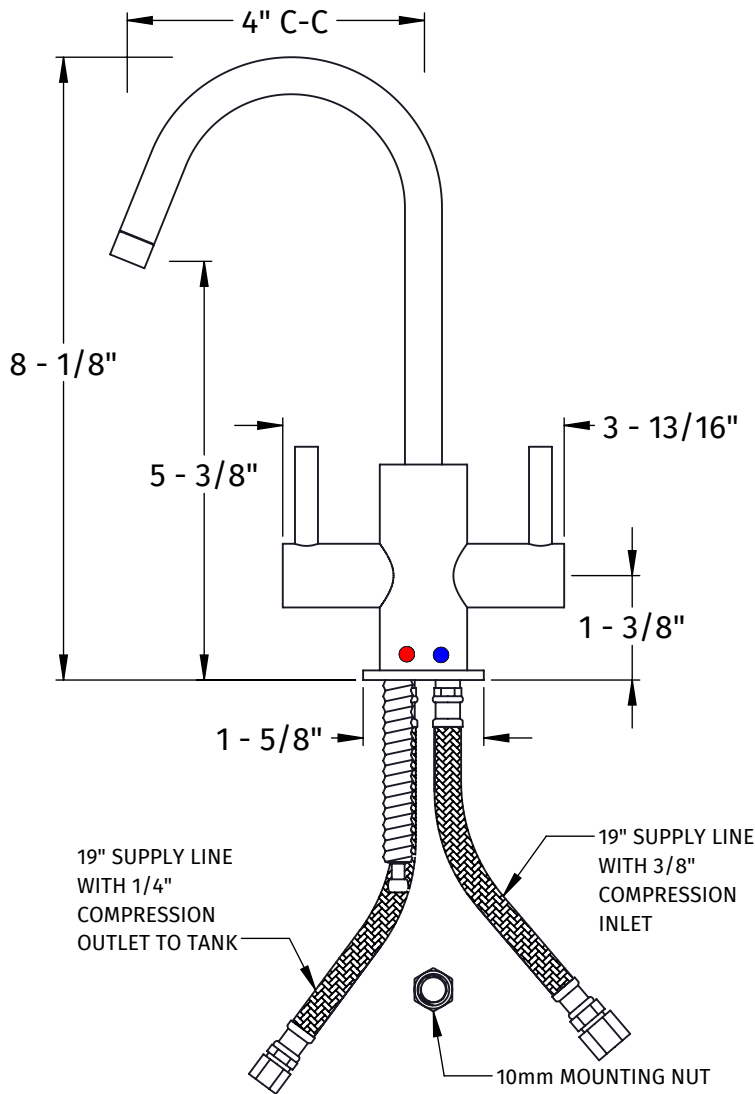

- MADE FROM SOLID STAINLESS STEEL WITH BRUSHED FINISH
- REQUIRES LITTLE GOURMET® HEATING TANK MT641-3 (SOLD SEPARATELY)
- FITS MOUNTING HOLE FROM 1 - 1/8" TO 1 - 1/2" DIAMETER
- NSF 61 & NSF 372 CERTIFIED, Q ≤ 1
- WILL FIT DECK UP TO 2 1/4" THICK
- 1/4 TURN CERAMIC CARTRIDGES (DHM32324-02, DHM32325-02)
- HANDLE IS NOT SPRING-LOADED
- REVERSE OSMOSIS SAFE (OPTIONAL AIR GAP AG1800 SOLD SEPARATELY)
- INCLUDES CONNECTION HARDWARE AND 2 FT SILICONE HOSE TO CONNECT HOT TANK (PART # RKDW-HOSEKIT)
- COMPATIBLE WITH MT1250XL, MT660, AND MT662 FILTRATION SYSTEMS (SOLD SEPARATELY)



MEETS THE AMERICANS WITH DISABILITIES ACT GUIDE-LINES AND ANSI A117.1 ACCESSIBLE AND USABLE BUILDINGS AND FACILITIES - CHECK LOCAL CODES

WARRANTY

FOR WARRANTY INFO PLEASE VISIT WWW.MOUNTAINPLUMBING.COM/PAGE/RESOURCES/WARRANTY

FINISH CARE & MAINTENANCE

NEVER USE ANY HARSH ALKALI, ACID BASED DETERGENTS OR CLEANERS SUCH AS SOFT SCRUB®, SCRUBBING BUBBLES® OR COMET® TO CLEAN. DO NOT USE BRILLO® OR SCOTCH BRITE® PADS. THESE WILL ALL HARM THE FINISH. TO CLEAN, USE ONLY A DAMP SOFT CLOTH AND WIPE GENTLY. STANDARD WINDEX® CAN ALSO BE USED SPARINGLY. IT IS NOT NECESSARY TO WIPE HARD TO REMOVE SPOTS. TO MAINTAIN THE FINISH, WIPE WITH A SOFT DRY CLOTH AFTER USE. AN OCCASIONAL COAT OF PURE CARNAUBA WAX WITHOUT CLEANERS WILL HELP PROTECT THE FINISH.

SPECIFICATIONS SUBJECT TO CHANGE WITHOUT NOTICE