

BDEXP1

FULLY PLATED BRASS BATH WASTE & OVERFLOW FOR CLAWFOOT TUBS

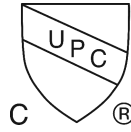

SPECIFICATION SHEET

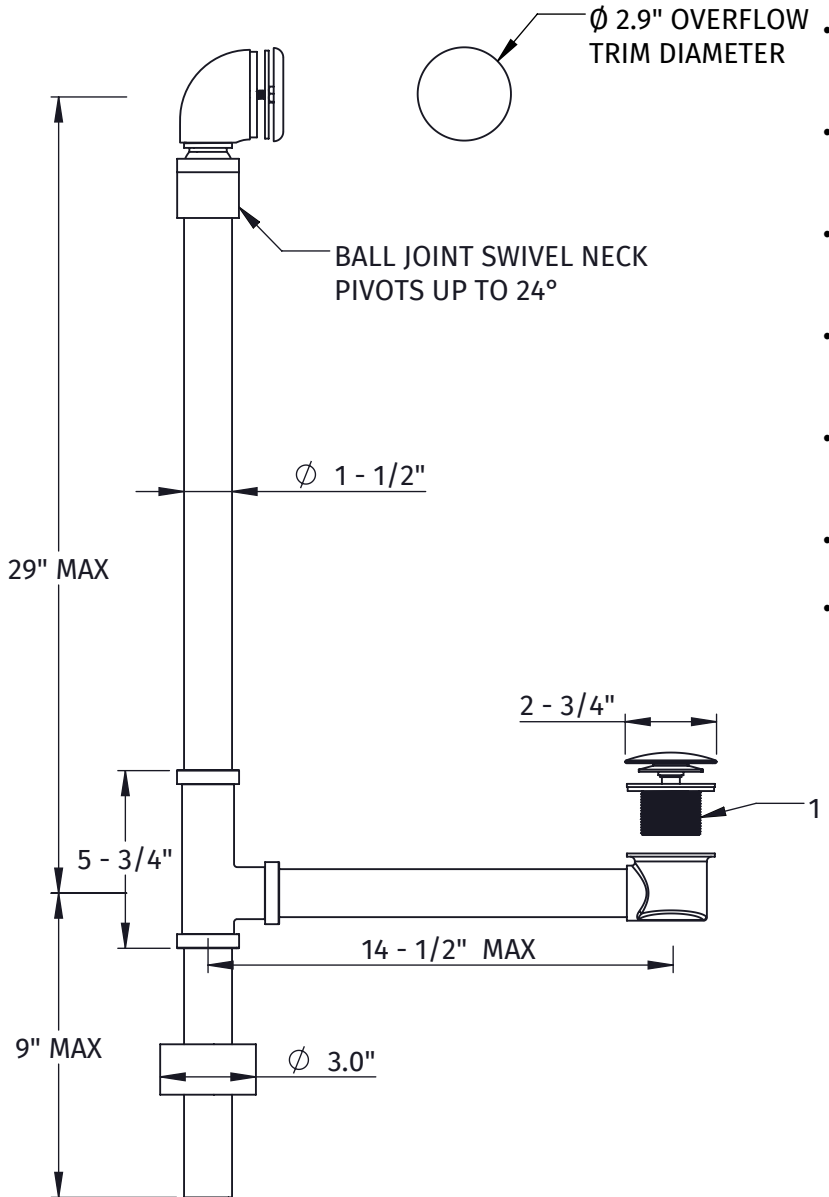

- ALL BRASS FITTINGS AND 17 GAUGE TUBE
- FULLY POLISHED AND PLATED FOR EXPOSED APPLICATIONS
- PIPE LENGTH CAN BE CUT TO FIT TUB ***TEST FIT BEFORE CUTTING***
- CONTEMPORARY STYLING WITH EZ CLICK™ DRAIN
- SWIVELING OVERFLOW NECK ADJUSTS TO FIT BATHTUB WALL
- 1 1/2" O.D. BRASS TAILPIECE
- FOR USE WITH 2" DRAIN AND OVERFLOW OPENINGS

WARRANTY

FOR WARRANTY INFO PLEASE VISIT WWW.MOUNTAINPLUMBING.COM/PAGE/RESOURCES/WARRANTY

FINISH CARE & MAINTENANCE

NEVER USE ANY HARSH ALKALI, ACID BASED DETERGENTS OR CLEANERS SUCH AS SOFT SCRUB®, SCRUBBING BUBBLES® OR COMET® TO CLEAN. DO NOT USE BRILLO® OR SCOTCH BRITE® PADS. THESE WILL ALL HARM THE FINISH. TO CLEAN, USE ONLY A DAMP SOFT CLOTH AND WIPE GENTLY. STANDARD WINDEX® CAN ALSO BE USED SPARINGLY. IT IS NOT NECESSARY TO WIPE HARD TO REMOVE SPOTS. TO MAINTAIN THE FINISH, WIPE WITH A SOFT DRY CLOTH AFTER USE. AN OCCASIONAL COAT OF PURE CARNAUBA WAX WITHOUT CLEANERS WILL HELP PROTECT THE FINISH.

SPECIFICATIONS SUBJECT TO CHANGE WITHOUT NOTICE